

Parts Index

* Not to scale

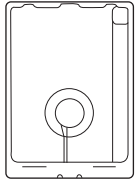

A

(1) Thin-Case™ Body



B

(1) Plug Insert



C

(3) #4-40 x 5/16" Machine Screws



D

(2) Nylock Nuts

- 1 How To Assemble:** Fully insert tablet into **(A) Thin-Case™ Body**. Press **(D) Nylock Nuts** into nut pockets of the **(B) Plug Insert**, nylon side facing up. Use a screwdriver if necessary to press the nuts flush.

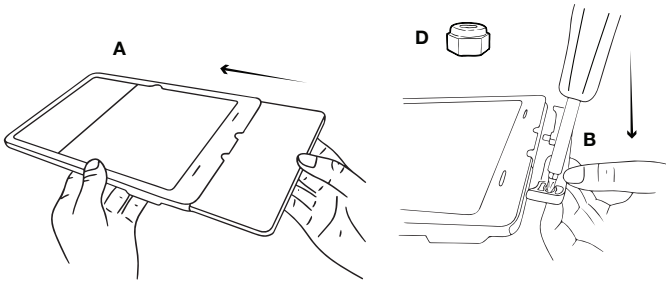

- 2** With nuts facing up, insert **(B) Plug Insert** into **(A) Thin-Case™ Body**, simultaneously plugging the connector into the tablet. Click components together to secure. Install **(C) Machine Screws** into the back holes of **(A) Thin-Case™ Body**. Fully tighten.

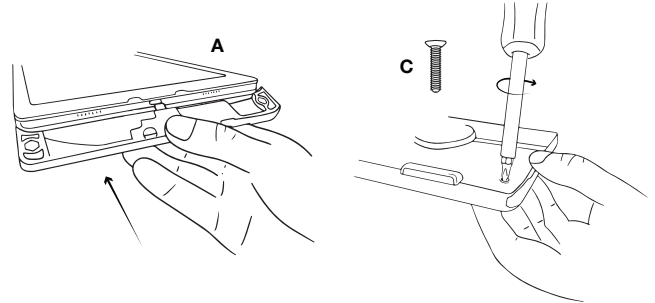

How To Disassemble: Remove the **(C) Machine Screws** from the **(A) Thin-Case™ Body**. Remove **(B) Plug Insert** by gently applying pressure to the device and pushing out.

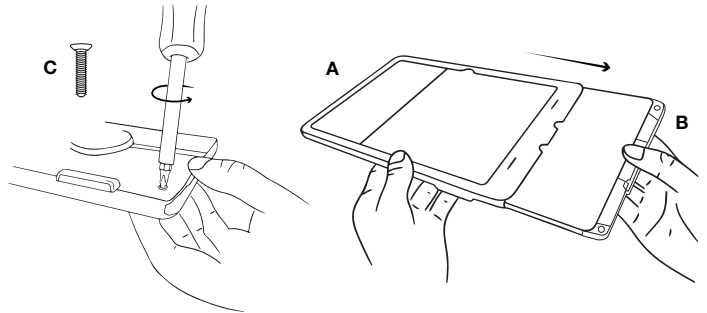

Patented & Pats. Pend.
rammount.com/ip



Safety Precaution

Do not install this product near or over an airbag deployment area or in a location that obstructs the driver's vision or interferes with vehicle operation. National Products, Inc. does not assume responsibility or liability for any such personal injury, death or property damage.

RAM® products are designed to function flawlessly, though there is always the potential a product may not function as expected. Product issues can often be resolved by the customer prior to sending in for warranty or replacement. If you experience issues, please follow the guidelines below:

Troubleshoot charging issues with your GDS® Dock™:

1. Verify that the power cord is securely plugged into the dock as well as the wall power source. Ensure that the power source is functional by testing with an alternate electronic device.
2. Verify that the IntelliSkin® connector is securely connected to your device.
3. Verify that the IntelliSkin® is seated properly in the receptacle of the GDS® Dock™.
4. After verifying the above steps, see below to verify that your GDS® Dock™ and IntelliSkin® have been properly cleaned.

GDS® General Care & Maintenance:

1. For spills or accumulated dirt on the GDS® Dock™ pogo pins, gently clean using contact cleaner or alcohol on a cotton swab. Use contact cleaner or alcohol with a stiff brush to clean IntelliSkin® contacts.
2. For industrial and heavy use environments, clean pogo pins and contacts on a regular basis.

3-year warranty on all electronic components / Lifetime Warranty on all non-electronic components

The exclusive NPI Lifetime Warranty states that all GDS® non-electronic components and parts are warranted against defect in materials and workmanship for the life of the product or part. NPI's Lifetime Warranty covers the product or its components only. The mount device is not covered under the Lifetime Warranty and will not be replaced if damaged as a result of mount failure. This warranty is expressly limited to persons in the United States, and all foreign countries who purchase GDS® for resale or use in the ordinary course of the buyer's business. This warranty does not cover any product or part that has been abused, worn out, heated, ground or otherwise altered, used for a purchase other than that for which it was intended, or used in a manner inconsistent with any instruction regarding its use.

GDS®, IntelliSkin®, GDS® Tech™, GDS® Technology™, GDS® Green™, Distinctive "Double Delta" Shape™, One Dock to Connect Them All™, GDS® Uni-Conn™, GDS® Tab-Conn™, GDS® Mobi-Conn™, and GDS® Compatible™ are trademarks or registered trademarks of National Products Inc. The distinctive Octagon, and D Shape of the GDS® connector is a trademark of National Products Inc. Patents and Trademarks: rammount.com/ip



RPR-INS-GDS-SKIN-TC-D-1