

Parts Index

* Not to scale



A

AMPS Adapter Plate



B

Top Post

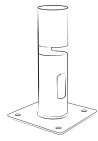

C

Base Plate
With Tube



D

Base Cover



E

Tube Cover



F

Screw
1/4"-20 x 5/8"



G

Barrel Nut
1/4"-20



H

(x4) Washers



I

Grease Packet

- 1** Drill clearance holes and install **(C) Base Plate** into desired surface.

Position each of the four **(H) Washers** between the **(C) Base Plate** and mounting surface. This will allow the **(D) Base Cover** to secure over the base when complete.

Mounting hardware is not included with this mount. Exact hardware type and length will vary depending on the surface it is mounted on. We recommend using through holes with 1/4"-20 or M6 size hardware with nuts and washers on the underside of the mounting surface.

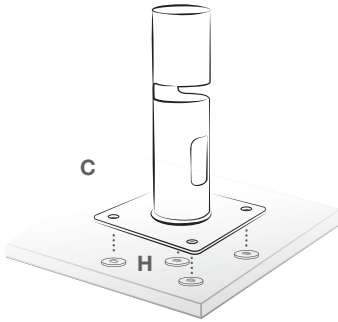

- 2** Using **(I) Grease Packet**, apply grease to shaded area inside of **(C) Tube**.

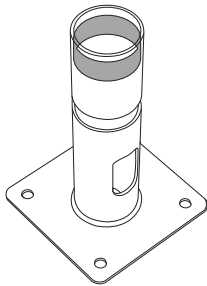

- 3** Connect **(A) AMPS Adapter Plate** to top of **(B) Top Post** using **(F) Screw** and **(G) Barrel Nut**.

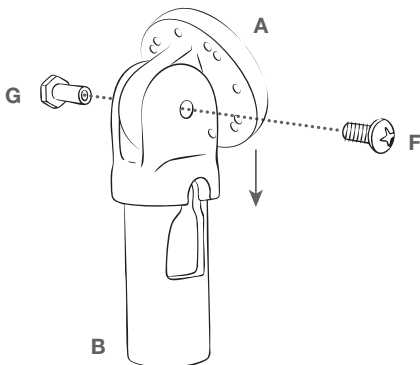

- 4** Before assembling remaining parts, determine which type of swivel functionality is desired looking at **(B) Top Post** and **(C) Base Plate**:

To enable a 180° swivel, align press-button of **(B) Top Post** with the slotted hole in **(C) Base Plate**.

To fix the mount in one direction, utilize the opposite single hole in **(C) Base Plate**.

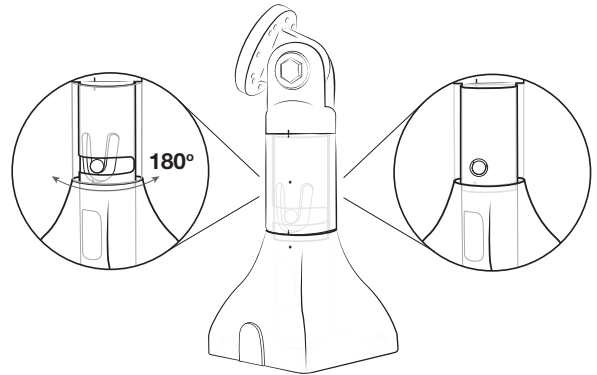

- 5** With **(D) Base Cover** and **(E) Tube Cover** positioned over **(C) Base Plate**, press **(B) Top Post** into hole, aligning the press-button with the desired hole determined in Step 4.

While inserting, the **(E) Tube Cover** may block your view of the press-button. As a reference, a small notch on the **(B) Top Post** is in line with the press-button.

A + B

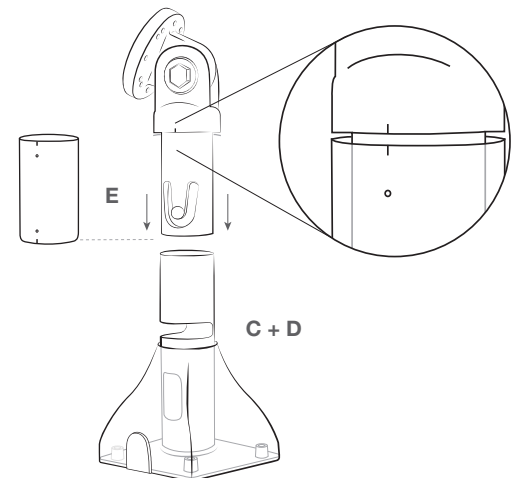

Disassembly Instructions

- 1 Align the notches on the **(E) Tube Cover** with the notch on the **(B) Top Post**. This will align the bottom hole with the press button.
- 2 Using a thin allen wrench or narrow tool, press into bottom hole against the press button. While pressing in, pull the **(B) Top Post** with **(A) AMPS Adapter Plate** up to remove from the base.

