

Item Number
RAM-VBD-101

RAM Drill Seat Bases

RAM Mounting Systems

SPECIFICATIONS

Placement

Flat surface/floor

Drilling Required

Yes

Seat Configuration

Bucket/Bench

Construction/Finish

Steel/Black Powdercoat

Dimensions

A = 20.25", B = 5.25", C = 5.5", D = 4"
Hole Center = 6.63"

Features

Universal base for any vehicle with a flat mounting surface

Misc.

Rugged Steel Construction

Lifetime warranty

RAM Mounting Systems

8410 Dallas Ave S
Seattle, WA 98108
Phone: (206) 763-8361
Fax: (206) 763-9615
www.rammount.com
support@rammount.com

Pole or Pedestal

Additionally purchased

Weight

6.4 lbs.



Shown In Use

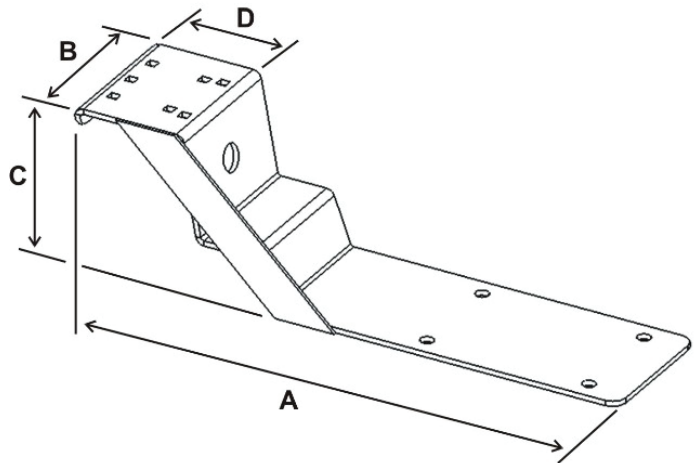

RAM-VBD-101



RMR-INS-VBD-101

Item Number
RAM-VBD-101

RAM Drill Seat Bases

RAM Mounting Systems

INSTALLATION INSTRUCTIONS

1. Place base on floor so that the pedestal is in the optimum location.
2. Mark the mounting hole locations. Please note that it might be necessary to shim a corner of the mounting base if the floor surface is uneven.
3. Drill 17/32" holes in the floor at all of the marked locations. Be extremely careful not to damage any equipment under the floor board of the vehicle when drilling.
4. Tighten base in place using bolts, washers, and nuts. If floor is less than 1/4" thick, please use fender washers on the underside to help distribute the weight.

The instructions below are for the installation and use of the stabilizer foot package:

The use of the stabilizer foot is recommended to reduce bounce in all applications. Simply replace the carriage bolts holding the pole system in place with the stabilizer foot. You will need a box wrench to tighten the hardware. The part number for the stabilizer foot kit is RAM-FOOT2-2. Slide the bolt through the foot, slide a lock washer over the thread so it rest on the foot. Place a nut over the thread and tighten to secure the foot over the head of the bolt. Next, thread a nut over the bolt and slide another lock washer over the bolt. Pass the foot up through the base from the bottom. Once through the base, slide the flat washer, lock washer, then thread the nut over the bolt. Position foot while hardware is loose so it is supporting the base off the floor. Once in position, tighten the nut so that it forces the foot down against the floor. Secure with remaining nut and washers on top.

RAM Mounting Systems
8410 Dallas Ave S
Seattle, WA 98108
Phone: (206) 763-8361
Fax: (206) 763-9615
www.rammount.com
support@rammount.com



RMR-INS-VBD-101