

## Specifications

### Placement

Passenger side on the floor, in front seat.

### Seat Configuration

Bucket

### Drilling Required

None - uses existing seat bolts.

### Construction/Finish

Steel/Black powder coat

### Dimensions

(A) 18" (B) 6.75" (C) 2.31"  
(Hole Center) 16"

### Pole or Pedestal

Purchased separately

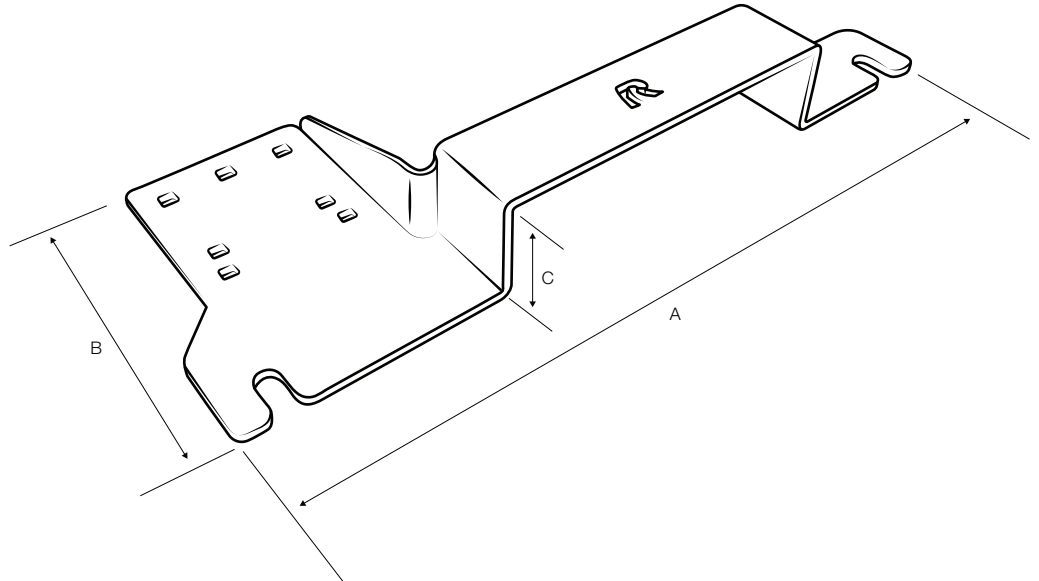

## Important Note

Utilizes existing vehicle hardware. Plastic trim may be re-installed once the RAM® No-Drill™ base has been secured into vehicle.

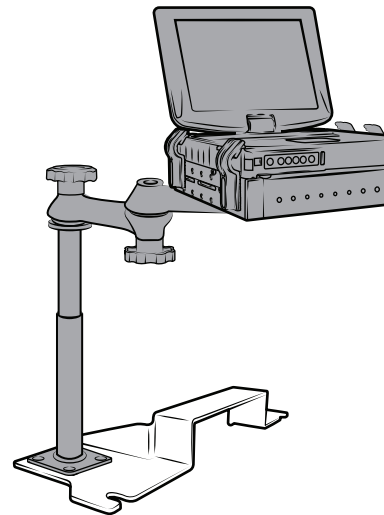

RMR-INS-VB-187



### Safety Precaution

Do not install this product near or over an airbag deployment area or in a location that obstructs the driver's vision or interferes with vehicle operation. National Products, Inc does not assume responsibility or liability for any such personal injury, death or property damage.

## Installation Instructions

If installing this base with a RAM® Tele-Pole™ assembly, attach the lower female pole prior to installing the RAM® No-Drill™ base. The carriage bolts should come up through the bottom with the rubber caps on the top side covering the nuts once attachment is complete.

- 1 Move the passenger side seat to its most forward position and only loosen the two seat track bolts using a 13MM socket wrench. Note that it is not necessary to completely remove ANY vehicle hardware during this installation. Just loosen it.
- 2 Move the passenger seat to its rearmost position and remove the plastic trim covers over the seat frame leg bolts. These pieces may be replaced after installation. A small flat head screw driver works well to remove these without damaging them.
- 3 Loosen the front seat leg bolts using a 13MM socket wrench. Using an extension with the socket wrench is recommended. Though not necessary, it is suggested that you use a T-20 torx bit and loosen the two plastic trim covers to allow the base to more easily slip underneath both the trim and the seat frame legs.
- 4 Gently lift the front of the seat to allow clearance for the base between the legs and the vehicle floor board. Slide the no drill base under the trim and seat frame leg. Push the base all the way under so the back side of the slots touches the seat leg bolts. Re-tighten the seat leg bolts. If you loosened the torx screws in the plastic trim, very gently re-tighten these screws as well.
- 5 Reinstall the plastic covers over the seat frame leg bolts. Move the seat forward once again and fully tighten the rear seat track bolts previously loosened.

Note that once installed, this base will slightly lessen the amount of forward travel available to the passenger side seat. Accessing the glove box is still possible once system is installed.

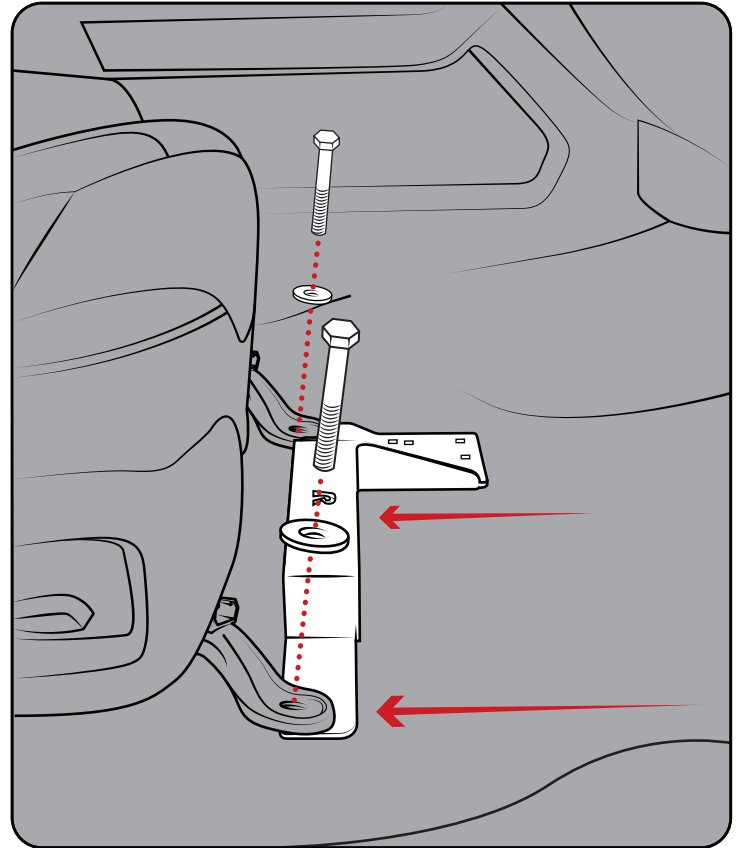

RMR-INS-VB-187



### Safety Precaution

Do not install this product near or over an airbag deployment area or in a location that obstructs the driver's vision or interferes with vehicle operation. National Products, Inc does not assume responsibility or liability for any such personal injury, death or property damage.