

**Parts Index**

\* Not to scale

Patent Pending  
rammount.com/ip

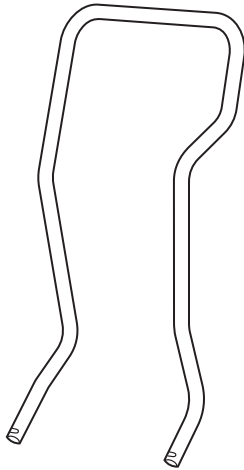

**A**  
Tough-Bar™

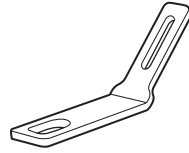

**B**  
(x2) Flat 45-Degree  
Base Connectors



**C**  
(x2) Seat Base Washers



**D**  
(x4) Base Connector Fillers

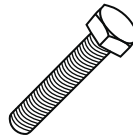

**E**  
(x2) M10 Bolts  
1.5 x 55mm

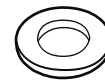

**F**  
(x2) M10 Flat Washers

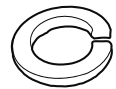

**G**  
(x2) M10 Lock Washers

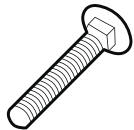

**H**  
(x2) Carriage Bolts



**I**  
(x2) Flat Washers  
1/4"



**J**  
(x2) Lock Washers  
1/4"



**K**  
(x2) Hex Nuts  
1/4" - 20



**L**  
(x2) Rubber Caps



**M**  
(x2) Machine Screws  
#6-32 x 1/2"



**N**  
(x2) Nylock Nuts  
#6-32



**O**  
(x8) Screws  
#8 x 5/8"

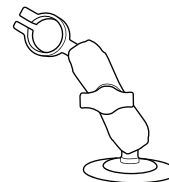

**P**  
(x2) Adhesive Dash Mounts



**Important Note**

Multiple bolt & screw connections are involved throughout this installation. For each step, loosely connect hardware so parts are held in place but can still be adjusted by hand. Do not fully tighten components until the final step, following the order instructed.

RMR-INS-TB9



**Safety Precaution**

Do not install this product near or over an airbag deployment area or in a location that obstructs the driver's vision or interferes with vehicle operation. Electronic devices attached to this product are not to be used while vehicle is in motion. National Products, Inc. does not assume responsibility or liability for any such personal injury, death, or property damage.

## 1 Vehicle Preassembly

1.1 Adjust both front seats to their rear-most position. Expose and remove front left passenger and front right driver seat bolts from vehicle.

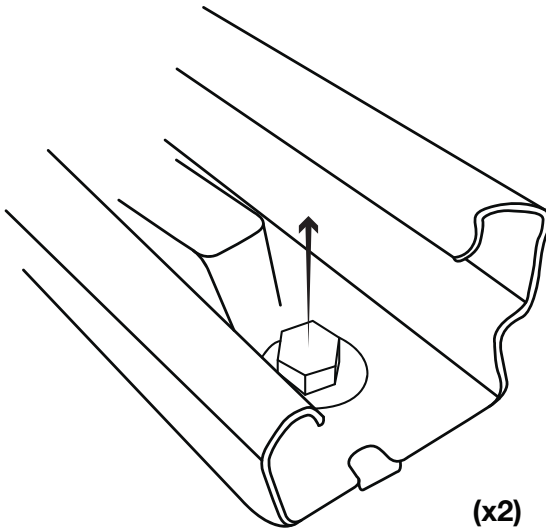

1.2 Position **(B) Base Connectors** over the exposed seat bolt holes. Position **(C) Seat Base Washers** over the holes of the base connectors. Secure to vehicle using **(E) Bolts**, **(F) Flat Washers** and **(G) Lock Washers**.

Do not fully tighten yet; allow ability to adjust.

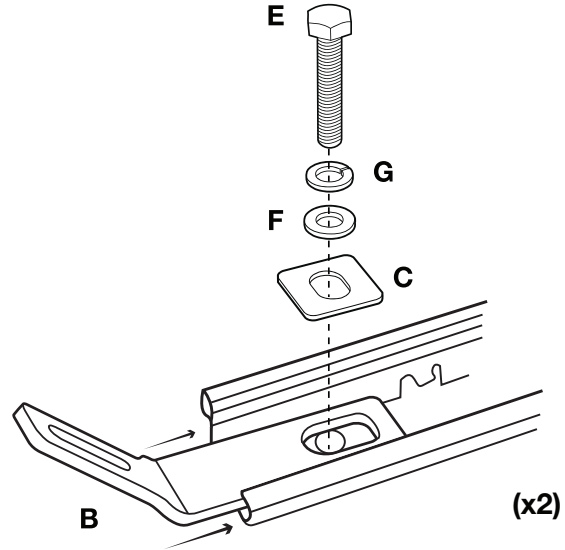

## 2 Tough-Bar™ Preassembly

2.1 Connect Ball Clamp Bases from **(P) Adhesive Dash Mounts** to the top of **(A) Tough-Bar™**, secure with **(M) Screws** and **(N) Nuts**.

Do not fully tighten yet.

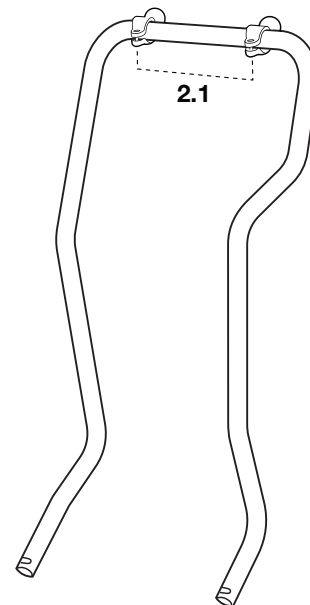
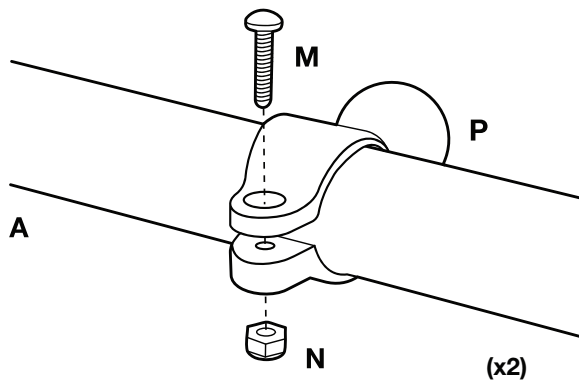

RMR-INS-TB9



### Safety Precaution

Do not install this product near or over an airbag deployment area or in a location that obstructs the driver's vision or interferes with vehicle operation. Electronic devices attached to this product are not to be used while vehicle is in motion. National Products, Inc. does not assume responsibility or liability for any such personal injury, death, or property damage.

### 3 Tough-Bar Installation

**3.1** Bring preassembled **(A) Tough-Bar™** into vehicle, aligning the bottom ends with the **(B) Base Connectors**. Insert **(D) Fillers** into the gaps of the base connectors. Secure with **(H) Bolts**, **(I) Flat Washers**, **(J) Lock Washers**, and **(K) Nuts**.

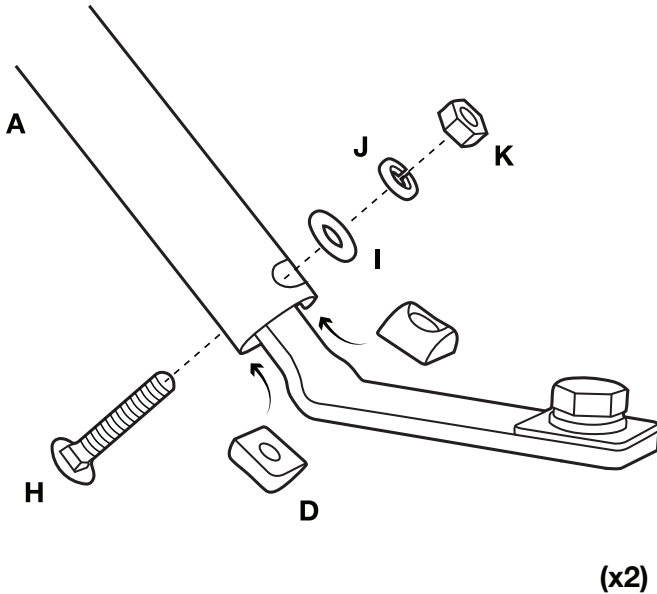

**3.2** Connect the Ball Clamp Bases to the Flex Adhesive Ball Bases using the Socket Arms from **(P) Dash Mounts**. Determine the placement of the Round Flex Bases on the dashboard, avoiding soft materials and narrow edges. Position the socket arms as perpendicular to the bar as possible.

**Do not apply adhesive yet.**

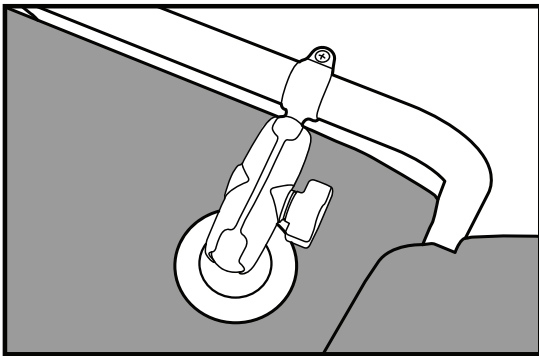

**3.3** Connect all additional mounts intended to be used with your Tough-Bar™ kit (tablet, laptop, phone & other mounts). Follow all mounting instructions provided with each additional component.

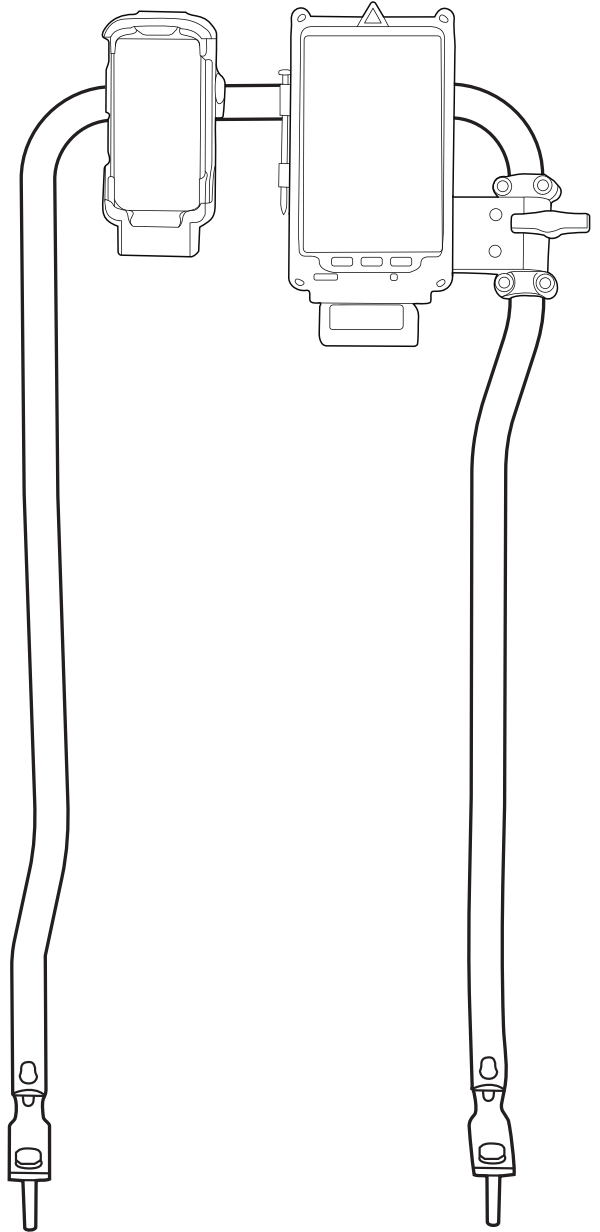

RMR-INS-TB9



#### Safety Precaution

Do not install this product near or over an airbag deployment area or in a location that obstructs the driver's vision or interferes with vehicle operation. Electronic devices attached to this product are not to be used while vehicle is in motion. National Products, Inc. does not assume responsibility or liability for any such personal injury, death, or property damage.

## 4 Inspection

Review your overall installation and ensure the following items have been checked:

- Tough-Bar™ and mounts do not block airbag deployment zone  
**(see instructions for any Friction Hinge Mounts)**
- Glove box remains accessible
- Gear shifter does not interfere with Tough-Bar™
- Seat adjustability and leg room is of suitable use
- Vertical segment on right side of Tough-Bar™ is vertical
- Horizontal segment along the top of the Tough-Bar™ is horizontal

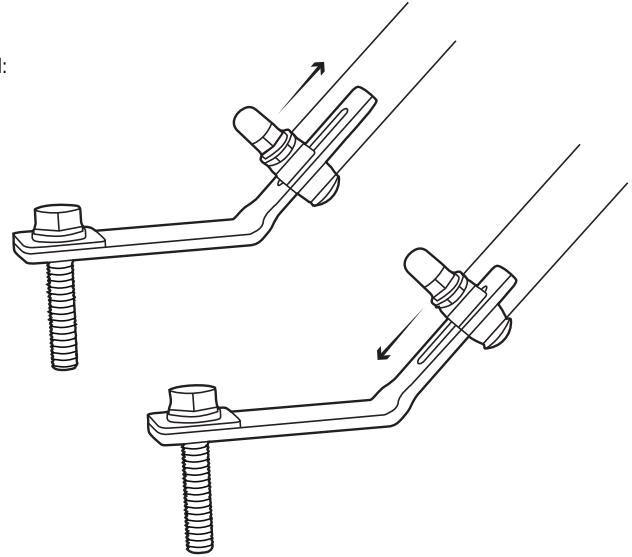

Make fine-tuned adjustments of your installation by sliding the Tough-Bar™ along the seat base connector slot to properly account for these items.

## 5 Fully Tighten & Final Connections

After full inspection and final adjustments, secure all components to your vehicle in the following order. Ensure proper alignment after each sequence:

1. Fully tighten **(H) Bolts** and **(K) Nuts** securing Tough-Bar™ to Base Connectors
2. Fully tighten **(E) Base Connector Bolts**
3. Cover excess threads on **(H) Bolts** with **(L) Rubber Caps**
4. Clean & dry dash surface and flex ball bases using included prep pads before applying adhesive.
5. Connect Adhesive pads to Flex Ball bases from **(P) Dash Mounts** and secure to dash. For best results, loosen the Flex Ball and heat the adhesive pad using a heat gun or hair dryer then stick to the dash and apply pressure.  
**Adhesive pads MUST be heated if the air temperature is below 70°F/21°C.**
6. For additional security, optional **(O) Screws** are provided to drill bases into dash if desired.
7. Fully tighten **(M) Screws** and **(N) Nuts** on the **(P) Dash Mount Clamp Bases**
8. Fully tighten **(P) Dash Mount Socket Arms**

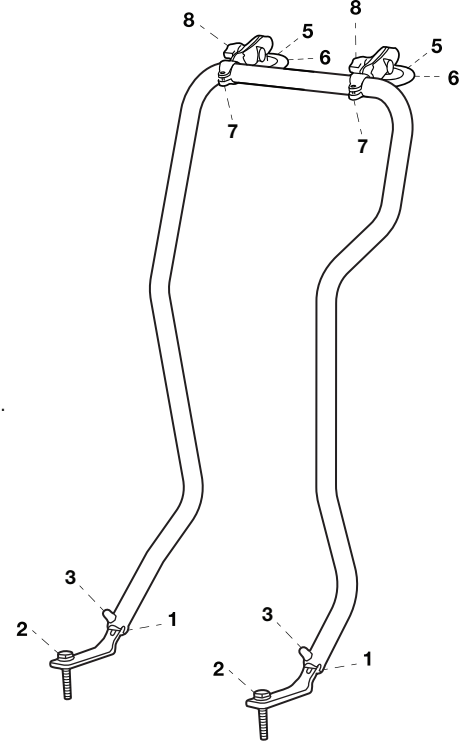

RMR-INS-TB9



### Safety Precaution

Do not install this product near or over an airbag deployment area or in a location that obstructs the driver's vision or interferes with vehicle operation. Electronic devices attached to this product are not to be used while vehicle is in motion. National Products, Inc. does not assume responsibility or liability for any such personal injury, death, or property damage.