

## Parts Index

\* not to scale

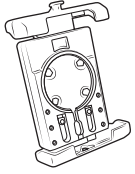

**A**  
(1) Quick-Grip™ Pro XL Holder

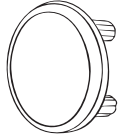

**B**  
(1) Anti-Slip Pad

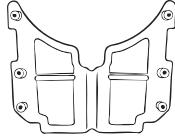

**C**  
(1) Anti-Slip Cover

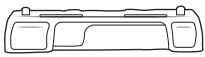

**D**  
(1) Thin Top Insert

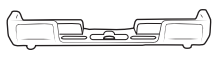

**E**  
(1) Thin Bottom Insert

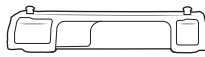

**F**  
(1) Thick Top Insert

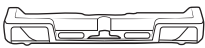

**G**  
(1) Thick Bottom Insert



**H**  
(1) Decal

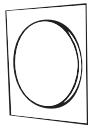

**I**  
(1) 53mm Adhesive Pad

Patented & Pats. Pend.  
rammount.com/ip

## Connect Your Phone

- Determine best fitting **Top Inserts (D or F)** and **Bottom Inserts (E or G)** for your phone. Once confirmed, install into **(A) Holder**.

### GENERAL RULE

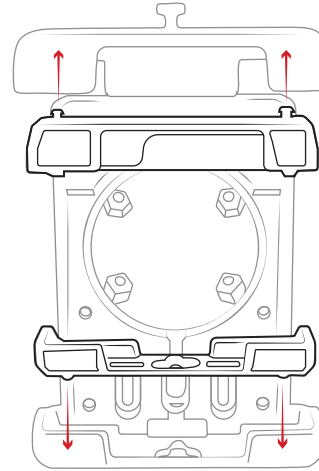

**D or F**

**E or G**



Small phones without case  
Use **Thick Inserts (F & G)**



Large phones without case  
Use **Thin Inserts (D & E)**



Phones with case and handheld PC's  
**No Inserts**

## For use with Wireless Charger

- Place **(I) Adhesive** on the back of your wireless charger and adhere to center cavity of **(A) Holder**. Route USB-C cable through bottom center hole.
- Place your phone in holder to ensure proper alignment with wireless charger. Adjust bottom support of **(A) Holder** as needed to better align phone with charger. Once aligned, cover cord with **(C) Anti-Slip Cover**.

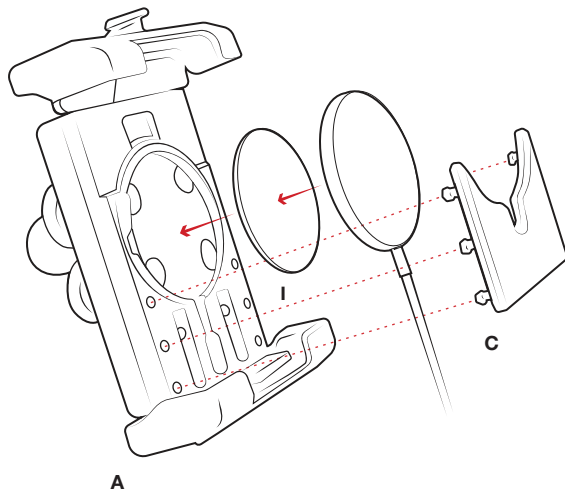

## For use without Wireless Charger

- Adhere optional **(H) Decal** onto **(B) Anti-Slip Pad**. Connect **(B) Pad** and **(C) Cover** onto the front of **(A) Holder**.

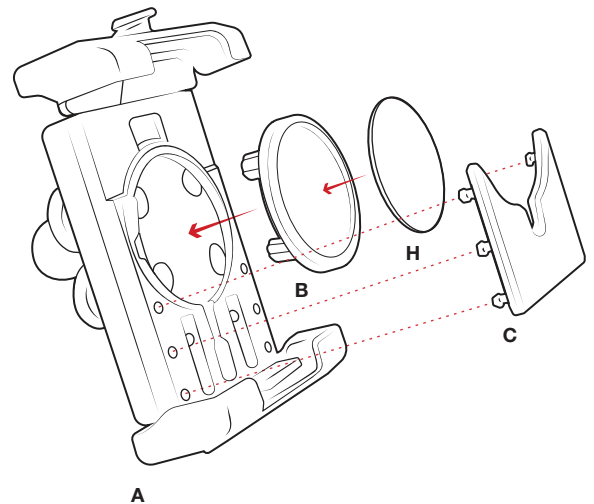

RMR-INS-PD7V